

NEOREST® WX1 Wall-Hung Toilet - 1.2 GPF / 0.8 GPF

FEATURES

NEOREST WX1

- Sleek, space-saving wall-hung Smart Bidet Toilet with integrated personal cleansing and comfort features
- CEFIONTECT® ceramic glaze minimizes waste from sticking to porous ceramic surfaces
- Ultra high-efficiency TORNADO FLUSH® system - 1.2 GPF / 0.8 GPF (4.5 LPF / 3.0 LPF)
- Auto flush - with back-up manual flush for power outages
- Universal Height, ADA compliant
- Touchless auto open/close lid
- EWATER+® auto-cleans wand, bowl, and under-seat after every use
- PREMIST® automatically mists the bowl before each use
- Self-cleaning wand cleans itself inside and out before and after every use
- CLEAN RESIN® keeps wand and seat cleaner, more hygienic, and effortless to maintain
- Gentle aerated, warm water, front and rear spray with oscillating and pulsating features
- Adjustable spray position, water temperature, and water pressure
- Instantaneous water heater for continuous warm water and energy savings
- Warm air dryer with five variable temperature settings
- Automatic air deodorizer
- Multifunction ergonomic stick-style remote control with personalized memory settings for up to 4 users
- Heated seat with temperature control
- Seamless seat design eliminates the gap where dirt collects
- Night light illuminates beneath the toilet and inside of the bowl
- Automatic and programmable energy saving systems

NEOREST In-Wall Tank Unit

- Ultra high-efficiency dual flushing system - 1.2 GPF / 0.8 GPF (4.5 LPF / 3.0 LPF)
- Adjustable 15"-19" mounting height
- Supports up to 880 lbs
- Commercial 2" x 6" or optional residential installation with 2" x 4" wall studs with waste outlet kit
- Copper pipe supply line

MODELS

- **CT9538CEFG**
Bowl Unit
- **SN9538M**
Top Unit
- **WT175MA**
In-Wall Tank System (Copper Pipe)
- **YT990#N**
Round Push Plate (Nickel)



TORNADO FLUSH



EWATER+



CEFIONTECT



AUTO FLUSH



UNIVERSAL HEIGHT



SKIRTED DESIGN

COLORS/FINISHES

- #01: Bowl and Top Unit in #01 Cotton
With YT990#N Nickel Push Plate

Made to order

- #MBL: Bowl and Top Unit in #MBL Matte Black
With YT990#B Black Push Plate
- #MW: Bowl and Top Unit in #MW Matte White
With YT990#W White Push Plate

CODES/STANDARDS

- Meets and exceeds:
 - Bowl/Seat: ASME A112.19.2/CSA B45.1, ASME A112.19.14, ASME A112.4.2/CSA B45.16, UL 1431 CSA C22.2 series
 - Carrier System: ASME A112.6.2
 - Tank Trim: IAPMO PS50, CSA B125.3, ASSE1002
- Certifications: IAPMO (cUPC®), EPA WaterSense®, State of Massachusetts, City of Los Angeles, and others
- Code Compliance: UPC, IPC, NSPC, NPC Canada, and others
- Legislative Compliance: California AB715, California Green Building Code, City of Los Angeles Water Efficiency Ordinance, and others
- ADA compliant for residential use when seat height is between 17" and 19"
- Complies with CA Prop 65 warning requirements



CWT9538CEMFG

NEOREST® WX1 Wall-Hung Toilet - 1.2 GPF / 0.8 GPF

YT990

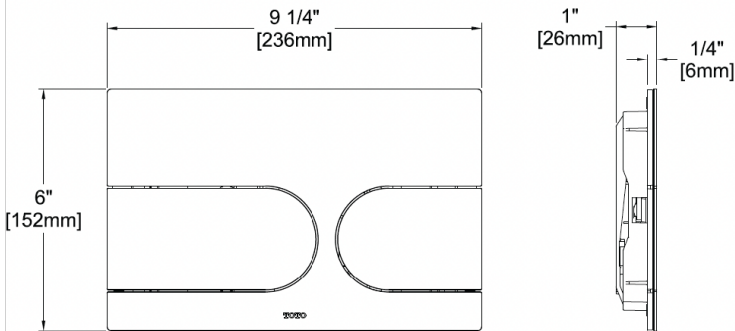

PRODUCT SPECIFICATION

- WT175MA
Adequate structural bracing is required. Framing support should be capable of supporting 880 lbs load without damage to the wall. See installation manual for more details.

Recommend to use plywood with a minimum thickness of 1/2" for the wall panel.

For use with potable water only. Do not use with recycled water.

It is highly recommended to use a surge protector to prevent damage in the event of a power surge. The following factors may affect IR signal strength and top unit operation: product and remote control location, room size, shape, construction materials, and degree of darkness (color) of ceiling and walls.

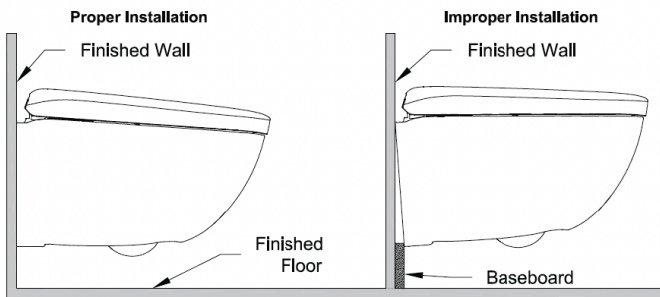

SPECIFICATIONS

WT175MA

Frame Work
Follow wall framing code around the Carrier

*Refer to Installation Manual on the specific Carrier height for the desired height of the toilet

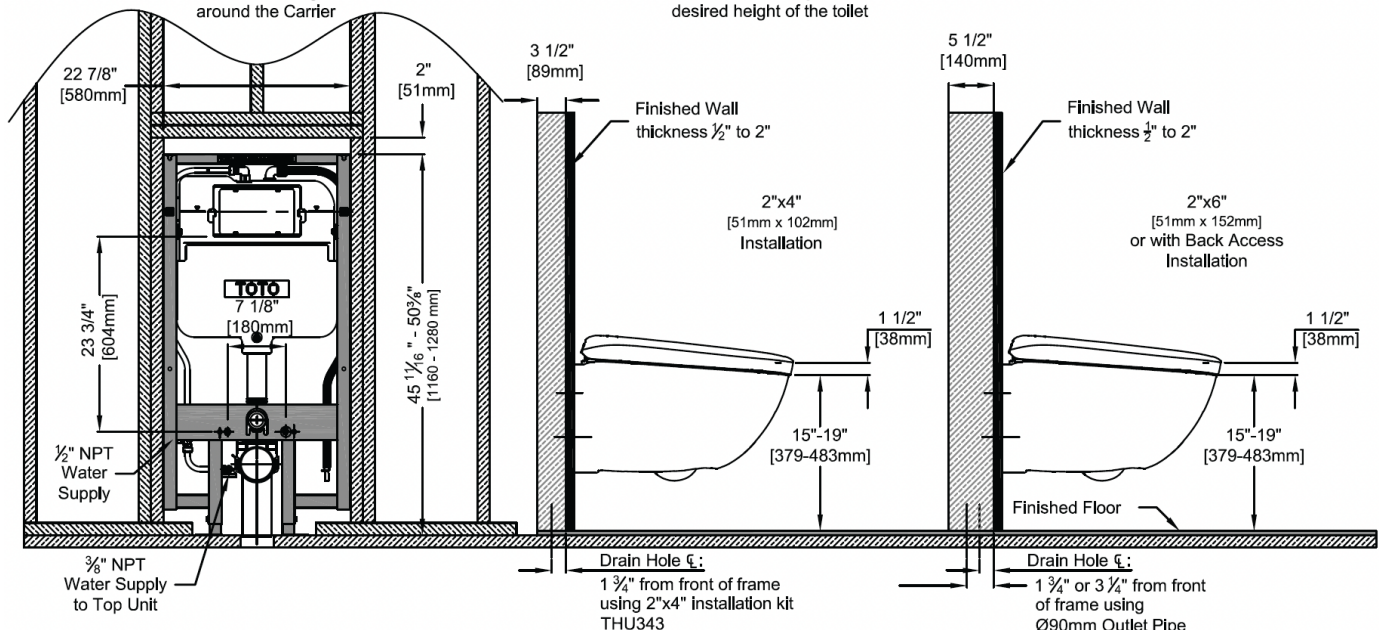

TOTO®

These dimensions and specifications are subject to change without notice